

AC100+ Gold® *Vinylester Injection Adhesive Anchoring System*

PRODUCT DESCRIPTION

The AC100+ Gold is a two-component vinylester adhesive anchoring system. The system includes injection adhesive in plastic cartridges, mixing nozzles, dispensing tools and hole cleaning equipment. The AC100+ Gold is designed for bonding threaded rod and reinforcing bar elements into drilled holes in concrete and masonry base materials.

GENERAL APPLICATIONS AND USES

- Bonding threaded rod and reinforcing bar into hardened concrete and masonry
- Evaluated for use in dry and water-saturated concrete including water filled holes
- Suitable to resist loads in cracked or uncracked concrete base materials for cases where anchor design theory and criteria applies
- Can be installed in a wide range of base material temperatures
- Qualified for seismic and wind loading (see ESR-2582)

FEATURES AND BENEFITS

- + Designed for use with threaded rod and reinforcing bar hardware elements
- + Consistent performance in low and high strength concrete (2,500 to 8,500 psi)
- + Evaluated and recognized for freeze/thaw performance
- + Evaluated and recognized for a range of embedments in interior and exterior applications
- + Versatile low odor formula with quick cure time
- + Evaluated and recognized for long term and short term loading (see performance tables)
- + Mixing nozzles proportion adhesive and provide simple delivery method into drilled holes
- + Cartridge design allows for multiple uses using extra mixing nozzles

APPROVALS AND LISTINGS

International Code Council, Evaluation Service (ICC-ES) ESR-2582 (Including FBC Supplement)
Code compliant with the 2009 IBC, 2009 IRC, 2006 IBC, 2006 IRC, 2003 IBC and 2003 IRC
Tested in accordance with ASTM E 488 and ICC-ES AC308 for use in structural concrete with ACI 318 Appendix D (Strength Design) and as amended by provisions of ICC-ES AC308 Annex A, Section 3.3 (www.icc-es.org)
Compliant with NSF/ANSI Standard 61 for drinking water system components – health effects; minimum requirements for materials in contact with potable water and water treatment
Conforms to requirements of ASTM C 881, Types I, II, IV and V, Grade 3, Classes A & B (meets Type III with exception of elongation)
Department of Transportation listings – see www.powers.com or contact transportation agency

GUIDE SPECIFICATIONS

CSI Divisions: 03 16 00 - Concrete Anchors, 04 05 19.16 - Masonry Anchors and 05 05 19 - Post-Installed Concrete Anchors. Adhesive anchoring system shall be AC100+ Gold as supplied by Powers Fasteners, Inc., Brewster, NY. Anchors shall be installed in accordance with published instructions and requirements of the Authority Having Jurisdiction.



SECTION CONTENTS Page No.

General Information	1
Installation Instructions	
Solid Base Materials	2
Hollow Base Materials	3
Reference Tables for Install	4
Installation Specifications	5
ASD Performance Data	6
Masonry Performance Data	8
SD Information	10
SD Performance Data	14
Ordering Information	19



AC100+ Gold coaxial cartridge with mixing nozzle



AC100+ Gold dual cartridge with mixing nozzle and extension

PACKAGING

Coaxial Cartridge

5 fl. oz. (150 ml or 9.2 in³)
10 fl. oz. (280 ml or 17.1 in³)

Dual (side-by-side Cartridge)

8 fl. oz. (235 ml or 14.3 in³)
12 fl. oz. (345 ml or 21.0 in³)
28 fl. oz. (825 ml or 50.3 in³)

STORAGE LIFE & CONDITIONS

Fifteen months in a dry, dark environment with temperature ranging from 32°F and 86°F (-0°C to 30°C)

ANCHOR SIZE RANGE (TYP.)

3/8" to 1-1/4" diameter threaded rod
No. 3 to No. 10 reinforcing bar (rebar)

SUITABLE BASE MATERIALS

Normal-weight Concrete
Grouted concrete masonry (CMU)
Hollow concrete masonry (CMU)
Brick masonry

INSTALLATION INSTRUCTIONS (SOLID BASE MATERIAL)

DRILLING

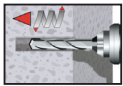

1- Drill a hole into the base material with a rotary hammer drill tool to the size and embedment required by the selected steel anchor element (see installation specifications for threaded rod and reinforcing bar in solid concrete base materials). The tolerances of the carbide drill bit should meet the requirements of ANSI Standard B212.15.

Precaution: Wear suitable eye and skin protection. Avoid inhalation of dust during drilling and/or removal.

Note! After drilling and prior to hole cleaning, all standing water in the drilled bore hole must be removed if present (e.g. vacuum, compressed air, etc.)

HOLE CLEANING BLOW 4x, BRUSH 4x, BLOW 4x

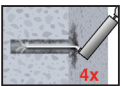

2a - Starting from the bottom or back of the anchor hole, blow the hole clean using a compressed air nozzle (min. 90 psi) or a hand pump (supplied by Powers Fasteners) a minimum of four times (4x).

- Use a compressed air nozzle (min. 90 psi) or a hand pump (min. volume 25 fl. oz.) for anchor rod 3/8" to 3/4" diameter or reinforcing bar (rebar) sizes #3 to #6.
- Use a compressed air nozzle (min. 90 psi) for anchor rod 7/8" to 1-1/4" diameter and rebar sizes #7 to #10. A hand pump shall not be used with these anchor sizes.

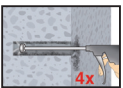

2b - Determine wire brush diameter (see hole cleaning equipment selection table) and attach the brush with adaptor to a rotary drill tool or battery screwgun. Brush the hole with the selected wire brush a minimum of four times (4x). A brush extension (supplied by Powers Fasteners, Cat. #08282) should be used for holes drilled deeper than the listed brush length.

The wire brush diameter should be checked periodically during use. The brush must be replaced if it becomes worn (less than D_{min}, see hole cleaning equipment selection table) or does not come into contact with the sides of the drilled hole.

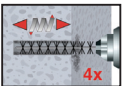

2c - Finally, blow the hole clean again a minimum of four times (4x).

- Use a compressed air nozzle (min. 90 psi) or a hand pump (min. volume 25 fl. oz.) for anchor rod 3/8" to 3/4" diameter or reinforcing bar (rebar) sizes #3 to #6.
- Use a compressed air nozzle (min. 90 psi) for anchor rod 7/8" to 1-1/4" diameter and rebar sizes #7 to #10. A hand pump shall not be used with these anchor sizes.

When finished the hole should be clean and free of dust, debris, ice, grease, oil or other foreign material.

PREPARING

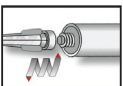

3- Check adhesive expiration date on cartridge label. Do not use expired product. Review Material Safety Data Sheet (MSDS) before use. Cartridge temperature must be between 32°F - 95°F (0°C - 35°C) when in use. Review gel (working) and cure time table. Consideration should be given to the reduced gel time of the adhesive in warm temperatures.

Attach a supplied mixing nozzle to the cartridge. Do not modify the mixer in any way and make sure the mixing element is inside the nozzle. Load the cartridge into the correct dispensing tool.

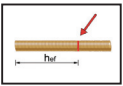

Note: Always use a new mixing nozzle with new cartridges of adhesive and also for all work interruptions exceeding the published working time of the adhesive.

4- Prior to inserting the anchor rod or rebar into the filled bore hole, the position of the embedment depth has to be marked on the anchor. Verify anchor element is straight and free of surface damage.

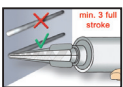

5- Adhesive must be properly mixed to achieve published properties. Prior to dispensing adhesive into the drilled hole, separately dispense at least three full strokes of adhesive through the mixing nozzle until the adhesive is a consistent **gray** color. Do not attach a used nozzle when changing to a new cartridge.

Review and note the published working and cure times (see gel time and curing time table) prior to injection of the mixed adhesive into the cleaned anchor hole.

INSTALLATION

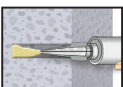

6- Fill the cleaned hole approximately two-thirds full with mixed adhesive starting from the bottom or back of the anchor hole. Slowly withdraw the mixing nozzle as the hole fills to avoid creating air pockets or voids. For embedment depth greater than 7-1/2" an extension nozzle must be used with the mixing nozzle.

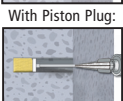

Piston plugs (see adhesive piston plug table) must be used with and attached to the mixing nozzle and extension tube for horizontal and overhead installations with anchor rod from 3/4" to 1-1/4" diameter and rebar sizes #6 to #10. Insert piston plug to the back of the drilled hole and inject as described in the method above. During installation the piston plug will be naturally extruded from the drilled hole by the adhesive pressure.

Attention! Do not install anchors overhead without proper training and installation hardware provided by Powers Fasteners. Contact Powers for details prior to use.

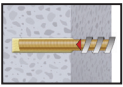

7- The anchor should be free of dirt, grease, oil or other foreign material. Push clean threaded rod or reinforcing bar into the anchor hole while turning slightly to ensure positive distribution of the adhesive until the embedment depth is reached. Observe the gel (working) time.

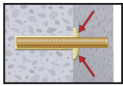

8- Be sure that the anchor is fully seated at the bottom of the hole and that some adhesive has flowed from the hole and all around the top of the anchor. If there is not enough adhesive in the hole, the installation must be repeated. The anchor shall not be moved after placement and during cure.

CURING AND LOADING

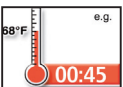

9- Allow the adhesive anchor to cure to the specified full curing time prior to applying any load (see gel time and curing time table).

Do not disturb, torque or load the anchor until it is fully cured.

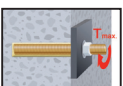

10- After full curing of the adhesive anchor, a fixture can be installed to the anchor and tightened up to the maximum torque (see installation specifications for threaded rod and reinforcing bar in solid concrete base material) by using a calibrated torque wrench.

Take care not to exceed the maximum torque for the selected anchor.

INSTALLATION INSTRUCTIONS (HOLLOW BASE MATERIAL)

DRILLING

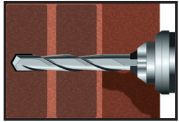

1- Drill a hole into the base material with a rotary drill tool to the size and embedment for the required screen size (see installation specifications for threaded rod in hollow concrete base material with screen tube supplied by Powers Fasteners). The tolerances of the drill bit used should meet the requirements of ANSI B212.15.

Precaution: Wear suitable eye and skin protection. Avoid inhalation of dust during drilling and/or removal.

HOLE CLEANING BLOW 2x, BRUSH 2x, BLOW 2x

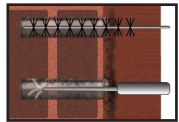

2- Starting from the bottom or back of the anchor hole, blow the hole clean with a hand pump (min. volume 25 fl.oz. supplied by Powers Fasteners) or compressed air nozzle a minimum of two times (2x).

- Determine the wire brush diameter (see hole cleaning equipment selection table) and attach the brush with adaptor to a rotary drill tool or battery screw gun. Brush the hole with the selected wire brush a minimum of two times (2x). A brush extension (supplied by Powers Fasteners, Cat #08282) should be used for holes drilled deeper than the listed brush length.

The wire brush should be checked periodically during use. The brush must be replaced if it becomes worn (less than D_{min} , see hole cleaning equipment selection table) or does not come in contact with sides of the drill hole.

- Finally, blow the hole clean again a minimum of two times (2x)

When finished the hole should be clean and free of dust, debris, ice, grease, oil or other foreign material.

PREPARING



3- Check adhesive expiration date on cartridge label. Do not use expired product. Review Material Safety Data Sheet (MSDS) before use. Cartridge temperature must be between 32°F - 95°F (0°C - 35°C) when in use. Review gel (working) time and curing time table. Consideration should be given to the reduced gel (working) time of the adhesive in warm temperatures.

Attach a supplied mixing nozzle to the cartridge. Do not modify the mixer in any way and make sure the mixing element is inside the nozzle. Load the cartridge into the correct dispensing tool.

Note: Always use a new mixing nozzle with new cartridges of adhesive and also for all work interruptions exceeding the published working time of the adhesive.

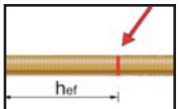

4- Prior to inserting the anchor rod into the filled screen tube, the position of the embedment depth has to be marked on the anchor. Verify anchor element is straight and free of surface damage.

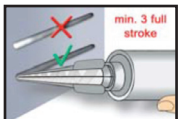

5- Adhesive must be properly mixed to achieve published properties. Prior to dispensing adhesive into the drilled hole, separately dispense at least three full strokes of adhesive through the mixing nozzle until the adhesive is a consistent **gray** color. Do not attach a used nozzle when changing to a new cartridge.

Review and note the published working and cure times (see gel time and curing time table) prior to injection of the mixed adhesive into the screen tube.

INSTALLATION



6- Insert a screen tube (supplied by Powers Fasteners) of suitable length into the cleaned anchor hole.



7- Fill the screen tube full with adhesive starting from the bottom or back of the tube. Slowly withdraw the mixing nozzle as the screen fills to avoid creating air pockets or voids. A plastic extension tube supplied by Powers Fasteners must be used with the mixing nozzle if the back of the screen tube cannot be reached.

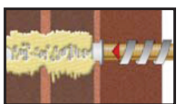

8- Prior to inserting the anchor rod into the screen tube inspect it to ensure that it is free of dirt, grease, oil or other foreign material.

Push the threaded rod into the screen tube while turning slightly to ensure positive distribution of the adhesive until back of the tube is reached.

CURING AND FIXTURE

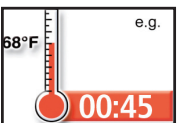

9- Allow the adhesive anchor to cure to the specified full curing time prior to applying any load.

Do not disturb, torque or load the anchor until it is fully cured (see gel time and curing time table).

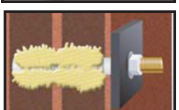

10- After full curing of the adhesive anchor, a fixture can be installed to the anchor and tightened up to the maximum torque (see installation specifications for threaded rod and reinforcing bar in hollow base material) by using a calibrated torque wrench.

Take care not to exceed the maximum torque for the selected anchor.

REFERENCE TABLES FOR INSTALLATION

Gel (working) Time and Curing Table

Temperature of base material		Gel (working) time	Full curing time
°F	°C		
14	-10	90 minutes	24 hours
23	-5	90 minutes	14 hours
32	0	45 minutes	7 hours
41	5	25 minutes	2 hours
50	10	15 minutes	90 minutes
68	20	6 minutes	45 minutes
86	30	4 minutes	25 minutes
95	35	2 minutes	20 minutes
104	40	1.5 minutes	15 minutes

The gel (working) times listed for 32 F to 95 F are also applicable for the temperature of the adhesive and use of mixing nozzles during installation. For installations in base material temperatures between 14 F and 23 F the cartridge temperature must be conditioned to between 68 F and 95 F (20 C - 35 C).

Hole Cleaning Equipment Selection Table for AC100+ Gold

Threaded rod diameter (inch)	Rebar size (no.)	ANSI drill bit diameter (inch)	Min. brush diameter, D _{min} (inches)	Brush length, L (inches)	Steel wire brush (Cat. #)	Blowout tool	Number of cleaning actions
Solid Base Material							
3/8	#3	7/16	0.475	6-3/4	08284	Hand-pump (Cat#08280) or compressed air nozzle	4x blowing 4x brushing
1/2	#4	9/16	0.600	6-3/4	08285		
5/8	#5	11/16	0.735	7-7/8	08286		
5/8	#5	3/4	0.780	7-7/8	08278		
3/4	#6	7/8	0.920	7-7/8	08287	Compressed air nozzle only	4x blowing
7/8	#7	1	1.045	11-7/8	08288		
1	#8	1-1/8	1.175	11-7/8	08289		
1-1/4	#9	1-3/8	1.425	11-7/8	08290		
-	#10	1-1/2	1.550	11-7/8	08291		
Hollow Base Material							
3/8	-	1/2	0.600	6-3/4	08285	Hand pump (Cat# 08280) or compressed air nozzle	2x blowing 2x brushing 2x blowing
3/8	--	5/8	0.735	7-7/8	08286		
1/2	-	5/8	0.735	7-7/8	08286		
1/2	--	3/4	0.780	7-7/8	08278		
5/8	-	3/4	0.780	7-7/8	08278		
5/8	-	7/8	0.920	7-7/8	08287		

An SDS-plus adaptor (Cat. #08283) or Jacobs chuck style adaptor (Cat. #08296) is required to attach a steel wire brush to the drill tool. A brush extension (Cat#08282) should be used for holes drilled deeper than the listed brush length.

Adhesive Piston Plugs

Threaded rod diameter (inch)	Rebar size (no.)	ANSI drill bit diameter (inch)	Plug Size (inch)	Plastic Plug (Cat. #)	Horizontal installations
3/4	#6	7/8	7/8	08300	
7/8	#7	1	1	08301	
1	#8	1-1/8	1-1/8	08303	
1-1/4	#9	1-3/8	1-3/8	08305	
-	#10	1-1/2	1-1/2	08309	

A plastic extension tube (3/8" dia.) must be used with piston plugs.

INSTALLATION SPECIFICATIONS

Allowable Stress Design (ASD) Installation Table for AC100+ Gold (Solid Concrete Base Materials)

Dimension/Property		Notation	Units	Nominal Anchor Size								
Threaded rod		-	-	3/8"	1/2"	5/8"	3/4"	7/8"	1"	-	1-1/4"	-
Reinforcing bar		-	-	#3	#4	#5	#6	#7	#8	#9	-	#10
Nominal anchor diameter		d	in. (mm)	0.375 (9.5)	0.500 (12.7)	0.625 (15.9)	0.750 (19.1)	0.875 (22.2)	1.000 (25.4)	1.125 (28.6)	1.250 (31.8)	1.250 (31.8)
Nominal diameter of drilled hole		d_{bit}	in.	7/16 ANSI	9/16 ANSI	11/16 or 3/4 ANSI	7/8 ANSI	1 ANSI	1-1/8 ANSI	1-3/8 ANSI	1-3/8 ANSI	1-1/2 ANSI
Minimum embedment depth		h_v	in. (mm)	2-3/8 (61)	2-3/4 (70)	3-1/8 (79)	3-1/2 (89)	3-1/2 (89)	4 (102)	4-1/2 (114)	5 (127)	5 (127)
Maximum torque ¹ (only possible after full cure time of adhesive)	A36 or F1554 carbon steel rod	T_{max}	ft.-lb. (N-m)	10 (13)	25 (34)	50 (68)	90 (122)	125 (169)	165 (224)	-	280 (379)	-
	F593 Condition CW stainless steel rod or ASTM A193, Grade B7 carbon steel rod	T_{max}	ft.-lb. (N-m)	16 (22)	33 (45)	60 (81)	105 (142)	125 (169)	165 (224)	-	280 (379)	-

1. For installations between the minimum edge distance and 5 anchor diameters, the tabulated maximum torque must be reduced (multiplied) by a factor of 0.45.

Allowable Stress Design (ASD) Installation Table for AC100+ Gold (Hollow Base Material with Screen Tube)

Dimensions/property	Notation	Units	Nominal Size - Stainless Steel			Nominal Size - Plastic		
			3/8"	1/2"	5/8"	3/8"	1/2"	5/8"
Nominal threaded rod diameter	d	in (mm)	0.375 (9.5)	0.500 (12.7)	0.625 (15.9)	0.375 (9.5)	0.500 (12.7)	0.625 (15.9)
Nominal screen tube diameter	-	in.	3/8	1/2	5/8	3/8	1/2	1/2
Nominal diameter of drilled hole	d_{bit}	in.	1/2 ANSI	5/8 ANSI	3/4 ANSI	9/16 ANSI	3/4 ANSI	7/8 ANSI
Maximum torque (only possible after full cure time of adhesive)	T_{max}	ft.-lb. (N-m)	10 (8)	10 (8)	10 (8)	10 (8)	10 (8)	10 (8)

Detail of Steel Hardware Elements used with Injection Adhesive System

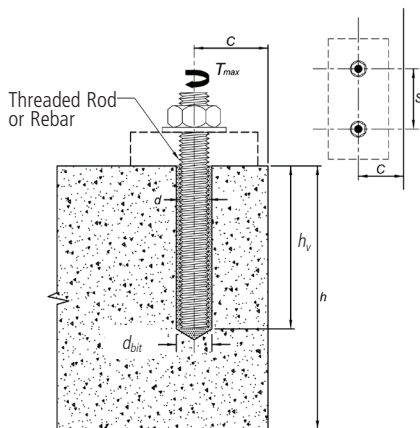

Nomenclature

- d = Diameter of anchor
- d_{bit} = Diameter of drill bit
- h = Base material thickness
The minimum value of h should be $1.5h_v$ or 3" whichever is greater
- h_v = Minimum embedment depth

Threaded Rod and Deformed Reinforcing Bar Material Properties

Steel Description (General)	Steel Specification (ASTM)	Nominal Anchor Size (inch)	Minimum Yield Strength, f_y (ksi)	Minimum Ultimate Strength, f_u (ksi)
Carbon rod	A 36 or F1554 Grade 36	3/8 through 1-1/4	36.0	58.0
Stainless rod (Alloy 304 / 316)	F 593, Condition CW	3/8 through 5/8	65.0	100.0
		3/8 through 1-1/4	45.0	85.0
High Strength Carbon rod	A 193 Grade B7	3/8 through 1-1/4	105.0	125.0
Grade 60 reinforcing bar	A 615, A 706, A 767, or A 996	3/8 through 1-1/4 (#3 through #10)	60.0	90.0
Grade 40 reinforcing bar	A 615 or A 767	3/8 through 1-1/4 (#3 through #6)	40.0	60.0

ADHESIVES

ASD PERFORMANCE DATA



Allowable Load Capacities for AC100+ Gold Installed into Normal-Weight Concrete with Threaded Rod and Reinforcing Bar (Based on Bond Strength/Concrete Capacity)^{1,2,3,4,5,6}

ADHESIVES

Nominal Rod Diameter or Rebar Size (in. or #)	Minimum Embedment Depth (in.)	Minimum Concrete Compressive Strength, (f'c)			
		3,000 psi	4,000 psi	5,000 psi	6,000 psi
		Tension (lbs)			
3/8 or #3	2-3/8	1,045	1,085	1,115	1,145
	3-1/2	1,540	1,600	1,645	1,685
	4-1/2	1,980	2,055	2,115	2,170
1/2 or #4	2-3/4	1,720	1,785	1,840	1,885
	4-3/8	2,740	2,845	2,925	2,995
	6	3,755	3,900	4,015	4,110
5/8 or #5	3-1/8	2,420	2,515	2,585	2,650
	5-1/4	4,140	4,300	4,425	4,530
	7-1/2	5,960	6,190	6,370	6,525
3/4 or #6	3-1/2	2,870	2,980	3,065	3,140
	6-1/4	5,795	6,015	6,190	6,340
	9	8,715	9,050	9,315	9,540
7/8 or #7	3-1/2	2,870	2,980	3,065	3,140
	7	7,905	8,205	8,450	8,650
	10-1/2	12,940	13,435	13,830	14,160
1 or #8	4	3,505	3,640	3,745	3,835
	8	10,030	10,410	10,720	10,975
	12	16,555	17,185	17,690	18,115
1-1/4 or #10	5	4,900	5,085	5,235	5,360
	10	14,200	14,740	15,175	15,540
	15	23,500	24,395	25,115	25,715

1. Allowable load capacities listed are calculated using an applied safety factor of 4.0 which includes assessment of freezing/thawing conditions and sensitivity to sustained loads (e.g. creep resistance). Consideration of safety factors of 10 or higher may be necessary depending on the application, such as life safety or overhead.
2. Linear interpolation may be used to determine allowable loads for intermediate embedments and compressive strengths.
3. The tabulated load values are applicable to single anchors installed at critical edge and spacing distances and where the minimum member thickness is 2.5 times the embedment depth.
4. The tabulated load values are applicable for dry concrete. Holes must be drilled with a hammer drill and an ANSI carbide drill bit. Installations in wet concrete or in water-filled holes may require a reduction in capacity. Contact Powers Fasteners for more information concerning these installation conditions.
5. Adhesives experience reductions in capacity at elevated temperatures. See the In-Service Temperature chart for allowable loads.
6. Allowable bond strength/concrete capacity must be checked against allowable steel strength to determine the controlling allowable load. Allowable shear capacity is controlled by allowable steel strength for the given conditions.

ASD PERFORMANCE DATA

Allowable Load Capacities for AC100+ Gold Installed into Normal-Weight Concrete with Threaded Rod and Reinforcing Bar (Based on Steel Strength)^{1,2,3}



Nominal Rod Diameter or Rebar Size (in. or #)	Steel Elements - Threaded Rod and Reinforcing Bar							
	A36 or F1554		A 193, Grade B7		F 593, CW (SS)		Grade 60 Rebar	
	Tension (lbs)	Shear (lbs)	Tension (lbs)	Shear (lbs)	Tension (lbs)	Shear (lbs)	Tension (lbs)	Shear (lbs)
3/8 or #3	1,485	760	3,085	1,585	2,565	1,315	2,655	1,320
1/2 or #4	2,725	1,395	5,655	2,900	4,685	2,410	4,710	2,345
5/8 or #5	4,325	2,225	8,990	4,625	7,480	3,845	7,370	3,670
3/4 or #6	6,420	3,295	13,320	6,845	9,465	4,865	10,592	5,285
7/8 or #7	8,855	4,550	18,390	9,445	13,070	6,715	14,425	7,195
1 or #8	11,630	5,970	24,115	12,395	17,150	8,810	18,840	9,400
#9	-	-	-	-	-	-	23,845	11,890
1-1/4	18,595	9,555	38,585	19,830	27,430	14,095	-	-
#10	-	-	-	-	-	-	29,435	14,680

1. Allowable load capacities listed are calculated for the steel element type. Consideration of applying additional safety factors may be necessary depending on the application, such as life safety or overhead.
2. Allowable bond strength/concrete capacity must be checked against allowable steel strength to determine the controlling allowable load.
3. Allowable shear capacity is controlled by steel strength for the given conditions described on the previous page.

In-Service Temperature Chart for Allowable Load Capacities¹

BASE MATERIAL TEMPERATURE		REDUCTION FACTOR FOR TEMPERATURE
°F	°C	
14	-10	1.00
23	-5	1.00
32	0	1.00
41	5	1.00
50	10	1.00
68	20	1.00
86	30	0.93
104	40	0.86
122	50	0.80
140	60	0.73
158	70	0.66
176	80	0.59

1. Linear interpolation may be used to derive reduction factors for base material temperatures between those listed.

ADHESIVES

MASONRY PERFORMANCE DATA



Allowable Load Capacities for Threaded Rod Installed with AC100+ Gold into Grout Filled Concrete Masonry^{1,2,3,4,5,6}

ADHESIVES

ANCHOR DIAMETER d (inch)	MINIMUM EMBEDMENT h_{nom} (inches)	MINIMUM EDGE DISTANCE (inches)	MINIMUM END DISTANCE (inches)	TENSION LOAD (pounds) Based on bond or masonry strength	Direction of Shear Loading	SHEAR LOAD (pounds) Based on bond or masonry strength	
ANCHOR INSTALLED INTO GROUTED MASONRY WALL FACES⁶							
3/8	3	3	4	735 ⁹	Any	490 ⁹	
		12	12	960 ⁹	Any	855 ⁹	
1/2	4	3	3	740	Any	455	
		4	4	985 ⁹	Any	655 ⁹	
		12	12	960	Any	1,425	
5/8	5	7-3/4 (Bed Joint)	3	935	Load to Edge	460	
		3	3	745	Any	410	
		12	12	1,095	Any	1,530	
3/4	6	7-3/4 (Bed Joint)	3	1,030	Load to Edge	590	
		4	4	790	Any	630	
		12	12	1,155	Any	1,565	
3/4	6	7-3/4 (Bed Joint)	4	945	Load to Edge	565	
		ANCHOR INSTALLED INTO TOPS OF GROUTED MASONRY WALLS⁷					
		1/2	2-3/4	1-3/4	4	595 ⁹	Any
4	1-3/4		4	520	Load to Edge	190	
5/8	5	1-3/4	4	740	Load to End	295	
					Any	235	
3/4	6	2-3/4	4	1,260	Load to Edge	410	
					Load to End	490	

For SI: 1 inch = 25.4 mm, 1 psi = 6.89 kPa, 1 lbf = 4.45 N.

1. Tabulated load values are for anchors installed in nominal 8-inch-wide (203 mm) Grade N, Type II, lightweight, medium-weight or normal-weight grout-filled concrete masonry units conforming to ASTM C 90. If the specified compressive strength of the masonry, f'_m , is 2,000 psi (13.8 MPa) minimum the tabulated values may be increased by 4 percent.
2. The tabulated allowable loads are permitted to be increased for wind and seismic by 33-1/3 percent.
3. Allowable bond or masonry strength in tension and shear are calculated using a safety factor of 5.0 and must be checked against the allowable tension and shear load capacities for threaded rod based on steel strength to determine the controlling factor.
4. The AC100+ Gold adhesive experiences a reduction in tensile and shear capacity with increased concrete temperature. Reduction factors must be applied to the allowable values based on bond or masonry strength noted in the table when the anchors are installed in locations where the in-service concrete temperature may be greater than 75°F (24°C).
5. Anchors may be installed in the grouted cells, cell webs and bed joints not closer than 1-inch from head joints.
6. The tabulated values are applicable for anchors installed into grouted masonry wall faces and masonry wall tops at a critical spacing distance, s_{cr} , between anchors of 3 times the embedment depth.
7. Anchor installations into tops of grouted masonry walls are limited to one per masonry cell.
8. The critical spacing for use with the anchor values shown in this table is 16 anchor diameters. For 1/2 - , 5/8 - and 3/4 - inch diameter anchors ,the spacing may be reduced to a minimum of 8 anchor diameters when using a tension reduction factor of 0.85 and a shear reduction factor of 0.45. Linear interpolation may be used for spacing distances between the minimum and critical distances.
9. Tabulated load values also apply to anchors installed in nominal 6-inch-wide (152 mm) Grade N, Type II, lightweight, medium-weight or normal-weight grout-filled concrete masonry units conforming to ASTM C 90. These tabulated load values may not be increased for wind and seismic.

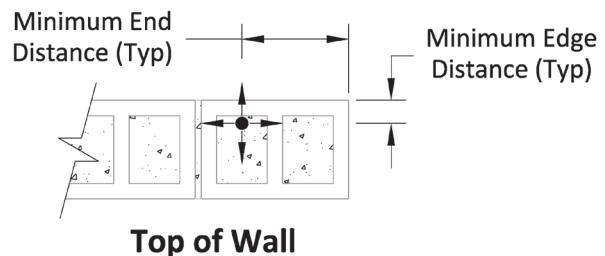
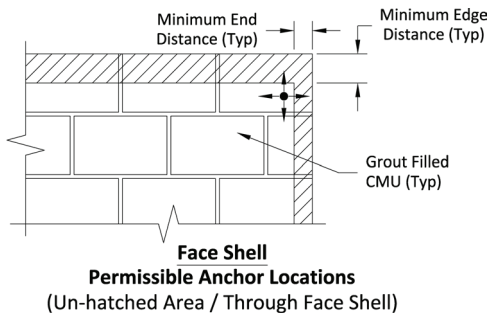

MASONRY PERFORMANCE DATA



Ultimate Load Capacities for Threaded Rod Installed with AC100+ Gold Into Hollow Concrete Masonry Walls with Stainless Steel and Plastic Screen Tubes^{1,2,3}

Rod Diameter <i>d</i> in. (mm)	Minimum Screen Tube Length in. (mm)	Minimum End Distance in. (mm)	Minimum Edge Distance in. (mm)	Ultimate Load		Allowable Load	
				Tension lbs. (kN)	Shear lbs. (kN)	Tension lbs. (kN)	Shear lbs. (kN)
3/8 (9.5)	2-3/4 (69.9)	12 (304.8)	12 (304.8)	1,600 (7.2)	3,530 (15.7)	320 (1.4)	705 (3.1)
	3-1/2 (88.9)	3-3/4 (95.2)	3-3/4 (95.2)	1,600 (7.2)	1,700 (7.6)	320 (1.4)	340 (1.5)
1/2 (12.7)	3-1/2 (88.9)	3-3/4 (95.2)	3-3/4 (95.2)	2,165 (9.6)	1,700 (7.6)	430 (1.9)	340 (1.5)
	3-1/2 (88.9)	12 (304.8)	12 (304.8)	2,165 (9.6)	4,710 (21.0)	430 (1.9)	940 (4.2)
5/8 (15.9)	4-1/2 (114.3)	3-3/4 (95.3)	3-3/4 (95.3)	2,735 (12.2)	-	550 (2.4)	-

1. Tabulated load values are for anchors installed in minimum 8" wide, Grade N, Type II, lightweight, medium-weight or normal-weight concrete masonry units conforming to ASTM C 90 that have reached a designated ultimate compressive strength at the time of installation ($f'm \geq 1,500$ psi). Mortar must be type N, S or M.
2. Allowable loads are calculated using an applied safety factor of 5.0. Consideration of safety factors of 10 or higher may be necessary depending on the application, such as life safety.
3. Anchor spacing is limited to one anchor per masonry cell.

Ultimate Load Capacities for Threaded Rod Installed with AC100+ Gold into the Face of Brick Masonry Walls^{1,2}

Rod Diameter <i>d</i> in. (mm)	Drill Diameter <i>d</i> _{bit} in. (in.)	Minimum Embedment Depth in. (mm)	Minimum End Distance in. (mm)	Minimum Edge Distance in. (mm)	Minimum Spacing in. (mm)	Ultimate Load		Allowable Load	
						Tension lbs. (kN)	Shear lbs. (kN)	Tension lbs. (kN)	Shear lbs. (kN)
3/8 (9.5)	1/2	3-1/2 (88.9)	6 (152.4)	6 (152.4)	6 (152.4)	5,845 (25.9)	4,580 (20.4)	1,170 (5.2)	915 (4.1)
1/2 (12.7)	5/8	6 (152.4)	8 (203.2)	8 (203.2)	8 (203.2)	11,500 (51.2)	9,300 (41.4)	2,300 (10.3)	1,860 (8.3)

1. Tabulated load values are for anchors installed in minimum 2 wythe, Grade SW, solid clay brick masonry conforming to ASTM C 62. Mortar must be N, S or M.
2. Allowable loads are calculated using all applied safety factor or 5.0. Consideration of safety factors of 10 or higher may be necessary depending on the application, such as life safety.

ADHESIVES

INSTALLATION SPECIFICATIONS



Strength Design Installation Table for AC100+ Gold

Dimension/Property	Notation	Units	Nominal Anchor Size									
			3/8"	1/2"	5/8"	3/4"	7/8"	1"	-	1-1/4"	-	
Threaded rod	-	-	3/8"	1/2"	5/8"	3/4"	7/8"	1"	-	1-1/4"	-	
Reinforcing bar	-	-	#3	#4	#5	#6	#7	#8	#9	-	#10	
Nominal anchor diameter	<i>d</i>	in. (mm)	0.375 (9.5)	0.500 (12.7)	0.625 (15.9)	0.750 (19.1)	0.875 (22.2)	1.000 (25.4)	1.125 (28.6)	1.250 (31.8)	1.250 (31.8)	
Nominal diameter of drilled hole	<i>d_o</i> , <i>d_{bit}</i>	in.	7/16 ANSI	9/16 ANSI	11/16 or 3/4 ANSI	7/8 ANSI	1 ANSI	1-1/8 ANSI	1-3/8 ANSI	1-3/8 ANSI	1-1/2 ANSI	
Minimum embedment ¹	<i>h_{ef,min}</i>	in. (mm)	2-3/8 (61)	2-3/4 (70)	3-1/8 (79)	3-1/2 (89)	3-1/2 (89)	4 (102)	4-1/2 (114)	5 (127)	5 (127)	
Maximum embedment ¹	<i>h_{ef,max}</i>	in. (mm)	4-1/2 (114)	6 (153)	7-1/2 (191)	9 (229)	10-1/2 (267)	12 (305)	13-1/2 (343)	15 (381)	15 (381)	
Minimum concrete member thickness ¹	<i>h_{min}</i>	in. (mm)	<i>h_{ef}</i> + 1-1/4 (<i>h_{ef}</i> + 30)			<i>h_{ef}</i> + 2 <i>d_o</i>						
Minimum spacing distance ^{1,2}	<i>s_{min}</i>	in. (mm)	1-7/8 (48)	2-1/2 (64)	3-1/8 (80)	3-3/4 (95)	4-3/8 (111)	5 (127)	5-5/8 (143)	6-1/4 (159)	6-1/4 (159)	
Minimum edge distance ¹	<i>c_{min}</i>	in. (mm)	1-3/4 (44)	1-3/4 (44)	1-3/4 (44)	1-3/4 (44)	1-3/4 (44)	1-3/4 (44)	2-3/4 (70)	2-3/4 (70)	2-3/4 (70)	
Maximum torque ² (only possible after full cure time of adhesive)	A36 or F1554 carbon steel rod	<i>T_{max}</i>	ft.-lb. (N-m)	10 (13)	25 (34)	50 (68)	90 (122)	125 (169)	165 (170)	-	280 (380)	-
	F593 Condition CW stainless steel rod, ASTM A193, Grade B7 carbon steel rod, ASTM A 449 Carbon Steel Rod	<i>T_{max}</i>	ft.-lb. (N-m)	16 (22)	33 (45)	60 (81)	105 (142)	125 (169)	165 (170)	-	280 (380)	-
	ASTM A 193 Grade B8/B8M Class 1	<i>T_{max}</i>	ft.-lb. (N-m)	5 (7)	20 (27)	40 (54)	60 (81)	100 (136)	165 (224)	-	280 (380)	-
	ASTM A 193 Grade B8/B8M2 Class 2B	<i>T_{max}</i>	ft.-lb. (N-m)	15 (20)	33 (45)	60 (82)	105 (143)	125 (170)	165 (224)	-	280 (380)	-

- For use with the design provisions of ACI 318 Appendix D and ICC-ES AC308 Annex A, Section 3.3 and ESR-2582.
- For installations between the minimum edge distance and 5 anchor diameters, the tabulated maximum torque must be reduced (multiplied) by a factor of 0.45.

Detail of Steel Hardware Elements used with Injection Adhesive System

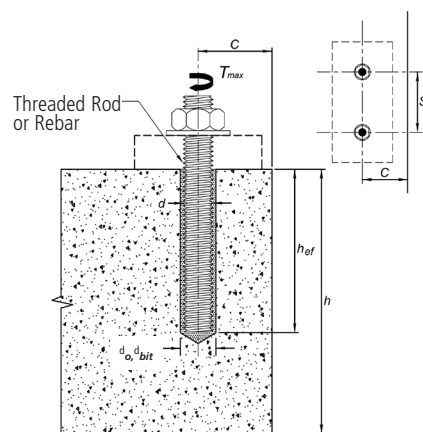

Threaded Rod and Deformed Reinforcing Bar Material Properties

Steel Description (General)	Steel Specification (ASTM)	Nominal Anchor Size (inch)	Minimum Yield Strength, <i>f_y</i> (ksi)	Minimum Ultimate Strength, <i>f_u</i> (ksi)
Carbon rod	ASTM A 36 and F 1554 Grade 36	3/8 through 1-1/4	36.0	58.0
	ASTM F 1554 Grade 55	3/8 through 1-1/4	55.0	75.0
	ASTM A 449	3/8 through 1 1-1/4	92.0 81.0	120.0 105.0
High Strength Carbon rod	ASTM A 193 Grade B7 and F 1554 Grade 105	3/8 through 1-1/4	105.0	125.0
Stainless rod (Alloy 304/316)	ASTM F 593 Condition CW	3/8 through 5/8 3/4 through 1-1/4	65.0 45.0	100.0 85.0
	ASTM A 193 Grade B8/B8M, Class 1	3/8 through 1-1/4	30.0	75.0
	ASTM A 193 Grade B8/B8M2, Class 2B	3/8 through 1-1/4	75.0	95.0
Reinforcing Bar	ASTM A 615, A 767, Grade 75	3/8 through 1-1/4 (#3 through #10)	75.0	100.0
	ASTM A 615, A 767, Grade 60	3/8 through 1-1/4 (#3 through #10)	60.0	90.0
	ASTM A 706, A 767, Grade 60	3/8 through 1-1/4 (#3 through #10)	60.0	80.0
	ASTM A 615, A 767, Grade 40	3/8 through 1-1/4 (#3 through #10)	40.0	60.0

STRENGTH DESIGN INFORMATION

Steel Tension and Shear Design Information for Threaded Rod and Reinforcing Bar in Normal Weight Concrete (For use with load combinations taken from ACI 318 Section 9.2)^{1,2,3}



DESIGN INFORMATION		SYMBOL	UNITS	NOMINAL ROD DIAMETER (inch)							
				3/8	1/2	5/8	3/4	7/8	1	-	1-1/4
				#3	#4	#5	#6	#7	#8	#9	#10
Minimum Embedment		$h_{et,min}$	in. (mm)	2-3/8 (60)	2-3/4 (70)	3-1/8 (79)	3-1/2 (89)	3-1/2 (89)	4 (102)	4-1/2 (114)	5 (127)
STEEL STRENGTH IN TENSION											
Effective cross sectional area of threaded rod		A_{se}	in. ² (mm ²)	0.078 (50)	0.142 (92)	0.226 (146)	0.335 (216)	0.462 (289)	0.606 (391)	-	0.969 (625)
Threaded Rod - Steel Strength in Tension	ASTM A 36 and F 1554 Grade 36	N_{sa}	lb (kN)	4,495 (20.0)	8,230 (36.6)	13,110 (58.3)	19,400 (86.3)	26,780 (119.1)	35,130 (156.3)	-	56,210 (250)
	ASTM F 1554 Grade 55	N_{sa}	lb (kN)	5,810 (25.9)	10,640 (47.3)	16,950 (75.4)	25,085 (111.6)	34,625 (154.0)	45,425 (202.0)	-	72,680 (323.3)
	ASTM A 449	N_{sa}	lb (kN)	9,300 (41.4)	17,025 (75.7)	27,120 (120.6)	40,140 (178.5)	55,905 (248.7)	63,600 (282.9)	-	101,755 (452.6)
	ASTM A 193 Grade B7 and F 1554, Grade 105	N_{sa}	lb (kN)	9,685 (43.1)	17,735 (78.9)	28,250 (125.7)	41,810 (186.0)	57,710 (256.7)	75,710 (336.8)	-	121,135 (538.8)
	ASTM F 593, Condition CW	N_{sa}	lb (kN)	7,750 (34.5)	14,190 (63.1)	22,600 (100.5)	28,430 (126.5)	39,245 (174.6)	51,485 (229.0)	-	82,370 (366.4)
	ASTM A 193 Grade B8/B8M, Class 1	N_{sa}	lb (kN)	4,420 (19.7)	8,090 (36.0)	12,880 (57.3)	19,065 (84.8)	26,315 (117.1)	34,525 (153.6)	-	55,240 (245.7)
	ASTM A 193 Grade B8/B8M2, Class 2B	N_{sa}	lb (kN)	7,365 (32.8)	13,480 (60.0)	21,470 (95.5)	31,775 (141.3)	43,860 (195.1)	57,545 (256.0)	-	92,065 (409.5)
Effective cross sectional area of reinforcing bars		A_{se}	in. ² (mm ²)	0.110 (71)	0.200 (129)	0.310 (200)	0.440 (284)	0.600 (387)	0.790 (510)	1.000 (645)	1.270 (819)
Reinforcing Bar - Steel Strength in Tension	ASTM A 615, Grade 75	N_{sa}	lb (kN)	11,000 (48.9)	20,000 (89.0)	31,000 (137.9)	44,000 (195.7)	60,000 (266.9)	79,000 (351.4)	100,000 (444.8)	127,000 (564.9)
	ASTM A 615, Grade 60	N_{sa}	lb (kN)	9,900 (44)	18,000 (80.1)	27,900 (124.1)	39,600 (176.1)	54,000 (240.2)	71,100 (316.3)	90,000 (400.3)	114,300 (508.4)
	ASTM A 706, Grade 60	N_{sa}	lb (kN)	8,800 (39.1)	16,000 (71.2)	24,800 (110.3)	35,200 (156.6)	48,000 (213.5)	63,200 (281.1)	80,000 (355.9)	101,600 (452.0)
	ASTM A 615, Grade 40	N_{sa}	lb (kN)	6,600 (29.4)	12,000 (53.4)	18,600 (82.7)	26,400 (117.4)	In accordance with ASTM A 615, Grade 40 bars are furnished only in sizes No. 3 through No. 6			
Reduction factor for steel strength		ϕ	-	0.75 (0.65 for F593, Condition CW & A615 reinforcing bar)							
STEEL STRENGTH IN SHEAR											
Threaded Rod - Steel Strength in Tension	ASTM A 36 and F 1554, Grade 36	V_{sa}	lb (kN)	2,695 (12.0)	4,940 (22.0)	7,860 (35.0)	11,640 (51.8)	16,070 (71.4)	21,080 (93.8)	-	33,725 (150.0)
	ASTM F 1554 Grade 55	V_{sa}	lb (kN)	3,485 (15.5)	6,385 (28.4)	10,170 (45.2)	15,050 (67.0)	20,775 (92.4)	27,255 (121.2)	-	43,610 (194.0)
	ASTM A 449	V_{sa}	lb (kN)	5,580 (24.8)	10,215 (45.4)	16,270 (72.4)	24,085 (107.1)	33,540 (149.2)	38,160 (169.7)	-	61,050 (271.6)
	ASTM A 193 Grade B7 and F 1554 Grade 105	V_{sa}	lb (kN)	5,815 (25.9)	10,640 (7.3)	16,950 (75.4)	25,085 (111.6)	34,625 (154.0)	45,425 (202.1)	-	72,680 (323.3)
	ASTM F 593	V_{sa}	lb (kN)	4,650 (20.7)	8,515 (37.9)	13,560 (60.3)	17,060 (75.9)	23,545 (104.7)	30,890 (137.4)	-	49,425 (219.8)
	ASTM A 193 Grade B8/B8M, Class 1	V_{sa}	lb (kN)	2,650 (11.8)	4,855 (21.6)	7,730 (34.4)	11,440 (50.9)	15,790 (70.2)	20,715 (92.1)	-	33,145 (147.4)
	ASTM A 193 Grade B8/B8M2, Class 2B	V_{sa}	lb (kN)	4,470 (19.7)	8,085 (36.0)	12,880 (57.3)	19,065 (84.8)	26,315 (117.1)	34,525 (153.6)	-	55,240 (245.7)
Reinforcing Bar - Steel Strength in Tension	ASTM A 615, Grade 75	V_{sa}	lb (kN)	6,600 (29.4)	12,000 (53.4)	18,600 (82.7)	26,400 (117.4)	36,000 (160.1)	47,400 (210.8)	60,000 (266.9)	76,200 (338.9)
	ASTM A 615, Grade 60	V_{sa}	lb (kN)	5,940 (26.4)	10,800 (48.0)	16,740 (74.5)	23,760 (105.7)	32,400 (144.1)	42,660 (189.8)	54,000 (240.2)	68,580 (305.0)
	ASTM A 706, Grade 60	V_{sa}	lb (kN)	5,280 (23.5)	9,600 (42.7)	14,880 (66.2)	21,120 (94.0)	28,800 (128.1)	37,920 (168.7)	48,000 (213.5)	60,960 (271.2)
	ASTM A 615, Grade 40	V_{sa}	lb (kN)	3,960 (17.6)	7,200 (32.0)	11,160 (49.6)	15,840 (70.5)	In accordance with ASTM A 615, Grade 40 bars are furnished only in sizes No. 3 through No. 6			
Reduction factor for steel strength		ϕ	-	0.65 (0.60 for F593, Condition CW & A615 reinforcing bar)							

1. The data in this table is intended to be used together with the design provisions of ACI 318 Appendix D and ICC-ES AC308 Annex A, Section 3.3 and ESR-2582.
 2. Installation must comply with published instructions and details. Periodic special inspection must be performed where required by code or the Authority Having Jurisdiction (AHJ). See ICC-ES AC308 Annex A, Section 14.4 and ESR-2582.
 3. For ductility classification of steel anchor elements see ESR-2582.

ADHESIVES

STRENGTH DESIGN INFORMATION



Concrete Tension Design Information for Threaded Rod and Reinforcing Bar in Normal-Weight Concrete (For use with load combinations taken from ACI 318 Section 9.2)^{1,2,3,4}

ADHESIVES

DESIGN INFORMATION	SYMBOL	UNITS	NOMINAL ROD DIAMETER (inch)								
			3/8	1/2	5/8	3/4	7/8	1	-	1-1/4	
			#3	#4	#5	#6	#7	#8	#9	#10	
Minimum Embedment	$h_{ef,min}$	in. (mm)	2-3/8 (60)	2-3/4 (70)	3-1/8 (79)	3-1/2 (89)	3-1/2 (89)	4 (102)	4-1/2 (114)	5 (127)	
CONCRETE BREAKOUT STRENGTH IN TENSION											
Effectiveness factor for cracked concrete	k_{cr}	-	Not applicable	17	17	17	17	17	17	17	
Effectiveness factor for uncracked concrete	k_{uncr}	-	24	24	24	24	24	24	24	24	
Modification factor for uncracked concrete	$\Psi_{c,N}$	-	For all design cases use $\Psi_{c,N} = 1.0$								
Critical edge distance	c_{ac}	in.	$c_{ac} = h_{ef} \cdot \left(\frac{\min(\tau_{k,uncr}; \tau_{k,max})}{1160} \right)^{0.4} \cdot \max \left[\left(3.1 - 0.7 \frac{h}{h_{ef}} \right); 1.4 \right]$								
		(mm)	$c_{ac} = h_{ef} \cdot \left(\frac{\min(\tau_{k,uncr}; \tau_{k,max})}{8} \right)^{0.4} \cdot \max \left[\left(3.1 - 0.7 \frac{h}{h_{ef}} \right); 1.4 \right]$								
Reduction factor for concrete breakout strength	ϕ	-	Condition B = 0.65								
BOND STRENGTH IN TENSION FOR TEMPERATURE RANGE A⁴ Maximum long term service temperature = 75° (24°C), Maximum short term service temperature = 104° (40°C)											
Dry hole	Reduction factor for bond strength	ϕ_d	-	0.65							
	Characteristic bond strength, cracked concrete (2,500 psi)	$\tau_{k,cr}$	psi (N/mm ²)	Not applicable	871 (6.0)	907 (6.3)	907 (6.3)	907 (6.3)	918 (6.3)	918 (6.3)	918 (6.3)
	Characteristic bond strength, uncracked concrete (2,500 psi)	$\tau_{k,uncr}$	psi (N/mm ²)	1,450 (10.0)	1,450 (10.0)	1,450 (10.0)	1,450 (10.0)	1,450 (10.0)	1,305 (9.0)	1,160 (8.0)	1,030 (7.1)
Water saturated hole	Reduction factor for bond strength	ϕ_{ws}	-	0.55							
	Additional factor for water saturated concrete	κ_{ws}	-	1.0	1.0	1.0	1.0	1.0	1.0	1.0	
Water-filled hole	Reduction factor for bond strength	ϕ_{wf}	-	0.45							
	Additional factor for water-filled hole condition	κ_{wf}	-	0.78	0.78	0.78	0.78	0.70	0.69	0.68	0.67
BOND STRENGTH IN TENSION FOR TEMPERATURE RANGE B⁴ Maximum long term service temperature = 122°F (50°C), Maximum short term service temperature = 176° (80°C)											
Dry hole	Reduction factor for bond strength	ϕ_d	-	0.65							
	Characteristic bond strength, cracked concrete (2,500 psi)	$\tau_{k,cr}$	psi (N/mm ²)	Not applicable	541 (3.7)	563 (3.9)	563 (3.9)	563 (3.9)	563 (3.9)	563 (3.9)	563 (3.9)
	Characteristic bond strength, uncracked concrete (2,500 psi)	$\tau_{k,uncr}$	psi (N/mm ²)	870 (6.0)	870 (6.0)	870 (6.0)	870 (6.0)	870 (6.0)	798 (5.5)	696 (4.8)	638 (4.4)
Water saturated hole	Reduction factor for bond strength	ϕ_{ws}	-	0.55							
	Additional factor for water saturated concrete	κ_{ws}	-	1.0	1.0	1.0	1.0	1.0	1.0	1.0	
Water-filled hole	Reduction factor for bond strength	ϕ_{wf}	-	0.45							
	Additional factor for water-filled hole condition	κ_{wf}	-	0.78	0.78	0.78	0.78	0.70	0.69	0.68	0.67

- The data in this table is intended to be used together with the design provisions of ACI 318 Appendix D and ICC-ES AC308 Annex A, Section 3.3 and ESR-2582.
- Installation must comply with published instructions and details. Periodic special inspection must be performed where required by code or the Authority Having Jurisdiction (AHJ). See ICC-ES AC308 Annex A, Section 14.4 and ESR-2582.
- Long term concrete temperatures are roughly constant over significant periods of time. Short-term elevated temperatures are those that occur over brief intervals, e.g. as a result of diurnal cycling.
- For load combinations consisting of short term loads only such as wind, bond strength may be increased by 40% for Temperature Range B.

STRENGTH DESIGN INFORMATION



Concrete Shear Design Information for Threaded Rod and Reinforcing Bar in Normal-Weight Concrete (For use with load combinations taken from ACI 318 Section 9.2)^{1,2,3}

DESIGN INFORMATION	SYMBOL	UNITS	NOMINAL ROD DIAMETER (inch) ¹							
			3/8	1/2	5/8	3/4	7/8	1	-	1-1/4
			#3	#4	#5	#6	#7	#8	#9	#10
Minimum Embedment	$h_{ef,min}$	in. (mm)	2-3/8 (60)	2-3/4 (70)	3-1/8 (79)	3-1/2 (89)	3-1/2 (89)	4 (102)	4-1/2 (114)	5 (127)
CONCRETE BREAKOUT STRENGTH IN SHEAR										
Load bearing length of anchor	l_e	in. (mm)	h_{ef} or $8d$, whichever is less							
Reduction factor for concrete breakout strength	ϕ	-	Condition B = 0.70							
PRYOUT STRENGTH IN SHEAR										
Coefficient for pryout strength	κ_{cp}	-	1.0 for $h_{ef} < 2.5$ in., 2.0 for $h_{ef} \geq 2.5$ in.							
Reduction factor for pryout strength	ϕ	-	Condition B = 0.70							

1. The data in this table is intended to be used together with the design provisions of ACI 318 Appendix D and ICC-ES AC308 Annex A, Section 3.3 and ESR-2582.
2. Installation must comply with published instructions and details. Periodic special inspection must be performed where required by code or the Authority Having Jurisdiction (AHJ). See ICC-ES AC308 Annex A, Section 14.4 and ESR-2582.
3. For load combinations consisting of short term loads only such as wind, bond strength may be increased by 40% for Temperature Range B.

Bond Strength Determination				
Concrete State	Hole Drilling Method	Installation Conditions	Bond Strength	Strength Reduction Factor
Uncracked concrete	Hammer Drill	Dry Concrete	$\tau_{k,uncr}$	ϕ_d
		Water-saturated concrete	$\tau_{k,uncr} \cdot \kappa_{ws}$	ϕ_{ws}
		Water-filled holes	$\tau_{k,uncr} \cdot \kappa_{wf}$	ϕ_{wf}
Cracked Concrete	Hammer Drill	Dry Concrete	$\tau_{k,cr}$	ϕ_d
		Water-saturated concrete	$\tau_{k,cr} \cdot \kappa_{ws}$	ϕ_{ws}
		Water-filled holes	$\tau_{k,cr} \cdot \kappa_{wf}$	ϕ_{wf}

ADHESIVES

STRENGTH DESIGN PERFORMANCE DATA

- Tabular values are provided for illustration and are applicable for single anchors installed in uncracked normal-weight concrete with minimum slab thickness, $h_a = h_{min}$, and with the following conditions:
 - c_{adj} is greater than or equal to the critical edge distance, c_{ac} where $c_{ac} = 2.7 h_{ef}$.
 - c_{adj} is greater than or equal to 1.5 times c_{adj} .
- Calculations were performed according to ACI 318-05 Appendix D and ICC-ES AC308 Annex A, Section 3.3. The load level corresponding to the failure mode is listed (e.g. For tension: steel, concrete breakout or bond strength; For shear: steel, concrete breakout or pryout strength). The lowest load level controls.
- Strength reduction factors (ϕ) for steel strength and concrete breakout strength are based on ACI 318 Section 9.2 for load combinations. Condition B was assumed.
- Strength reduction factors (ϕ) for bond strength are determined from reliability testing and qualification in accordance with ICC-ES AC308 and are tabulated in this product information and in ESR-2582.
- Tabular values are permitted for static loads only, seismic loading is not considered with these tables. Periodic special inspection must be performed where required by code or the Authority Having Jurisdiction (AHJ). See ICC-ES AC308 Annex A, Section 14.4 and ESR-2582.
- Tabular values are not permitted for anchors subjected to tension resulting from sustained loading. Please see ICC-ES AC308 Annex A, Section 3.3 and ESR-2582 for the supplement design requirement for this loading condition.
- For designs that include combined tension and shear, the interaction of tension and shear loads must be calculated in accordance with ACI 318-05 Appendix D.
- Interpolation is not permitted to be used with the tabular values. For intermediate base material compressive strengths, please see ACI 318-05 Appendix D, ICC-ES AC308 Annex A, Section 3.3 and information included in this product supplement. For other design conditions including seismic considerations please see ACI 318-05 Appendix D and ICC-ES AC308 Annex A, Section 3.3 and ESR-2582.
- Long term concrete temperatures are roughly constant over significant periods of time. Short-term elevated temperatures are those that occur over brief intervals, e.g. as a result of diurnal cycling.



ADHESIVES

Tension and Shear Design Strength Installed in Uncracked Concrete, Drilled with a Hammer-Drill and Carbide Bit in a Dry Hole Condition, for Temperature Range A (Bond or Concrete Strength)
 Maximum long term service temperature = 75°F (24°C), Maximum short term service temperature = 104°F (40°C)

		Minimum Concrete Compressive Strength, f'c (psi)									
Nominal Rod/Rebar Size (in. or #)	Embed. Depth h_{ef} (in.)	2,500		3,000		4,000		6,000		8,000	
		ϕN_{cb} or ϕN_s Tension (lbs.)	ϕV_{cb} or ϕV_{cp} Shear (lbs.)	ϕN_{cb} or ϕN_s Tension (lbs.)	ϕV_{cb} or ϕV_{cp} Shear (lbs.)	ϕN_{cb} or ϕN_s Tension (lbs.)	ϕV_{cb} or ϕV_{cp} Shear (lbs.)	ϕN_{cb} or ϕN_s Tension (lbs.)	ϕV_{cb} or ϕV_{cp} Shear (lbs.)	ϕN_{cb} or ϕN_s Tension (lbs.)	ϕV_{cb} or ϕV_{cp} Shear (lbs.)
3/8 or #3	2-3/8	2,635	1,860	2,695	2,035	2,790	2,350	2,930	2,880	3,030	3,265
	3	3,330	2,565	3,405	2,810	3,525	3,245	3,700	3,975	3,830	4,590
	4-1/2	4,995	4,255	5,105	4,660	5,285	5,380	5,550	6,590	5,745	7,610
1/2 or #4	2-3/4	3,555	2,480	3,895	2,715	4,310	3,135	4,520	3,840	4,680	4,435
	4	5,920	4,230	6,055	4,630	6,265	5,350	6,580	6,550	6,810	7,565
	6	8,885	7,150	9,080	7,835	9,400	9,045	9,865	11,080	10,215	12,795
5/8 or #5	3-1/8	4,310	3,260	4,720	3,570	5,450	4,125	6,425	5,050	6,650	5,830
	5	8,720	6,420	9,460	7,030	9,790	8,120	10,280	9,945	10,640	11,480
	7-1/2	13,880	10,945	14,185	11,990	14,685	13,840	15,415	16,955	15,960	19,575
3/4 or #6	3-1/2	5,105	4,350	5,595	4,765	6,460	5,500	7,910	6,740	8,935	7,780
	6	11,465	9,365	12,560	10,255	14,095	11,845	14,800	14,505	15,320	16,750
	9	19,985	15,905	20,430	17,425	21,145	20,120	22,200	24,640	22,980	28,455
7/8 or #7	3-1/2	5,105	4,770	5,595	5,225	6,460	6,035	7,910	7,395	9,135	8,535
	7	14,445	12,685	15,825	13,895	18,275	16,045	20,145	19,650	20,850	22,690
	10-1/2	26,540	21,580	27,805	23,640	28,780	27,295	30,215	33,430	31,280	38,600
1 or #8	4	6,240	6,195	6,835	6,790	7,895	7,840	9,665	9,600	11,160	11,085
	8	17,650	16,510	19,335	18,085	22,325	20,885	23,680	25,580	24,510	29,535
	12	31,980	28,115	32,685	30,795	33,835	35,560	35,520	43,555	36,770	50,290
#9	4-1/2	7,445	8,090	8,155	8,860	9,420	10,230	11,535	12,530	13,320	14,465
	9	21,060	21,295	23,070	23,325	25,375	26,935	26,640	32,985	27,575	38,090
	13-1/2	35,975	36,065	36,770	39,510	38,065	45,620	39,960	55,875	41,365	64,515
1 1/4	5	8,720	9,605	9,555	10,525	11,030	12,150	13,510	14,880	15,115	17,185
	10	24,665	25,670	26,875	28,125	27,815	32,475	29,205	39,770	30,230	45,925
	15	39,435	43,775	40,310	47,950	41,725	55,370	43,805	67,810	45,345	78,305
#10	5	8,720	9,915	9,555	10,860	11,030	12,545	13,510	15,360	15,115	17,740
	10	24,665	26,175	26,875	28,675	27,815	33,110	29,205	40,550	30,230	46,825
	15	39,435	44,390	40,310	48,625	41,725	56,150	43,805	68,765	45,345	79,405

Legend Concrete Breakout Strength Bond Strength/Pryout Strength

STRENGTH DESIGN PERFORMANCE DATA

Tension and Shear Design Strength Installed in Uncracked Concrete, Drilled with a Hammer-Drill and Carbide Bit in a Dry Hole Condition, for Temperature Range B (Bond or Concrete Strength) -see notes on previous page



Maximum long term service temperature = 122°F (50°C), Maximum short term service temperature = 176°F (80°C)

Nominal Rod/Rebar Size (in. or #)	Embed. Depth h_{ef} (in.)	Minimum Concrete Compressive Strength, f'_c (psi)									
		2,500		3,000		4,000		6,000		8,000	
		ϕN_{cb} or ϕN_a Tension (lbs.)	ϕV_{cb} or ϕV_{cp} Shear (lbs.)	ϕN_{cb} or ϕN_a Tension (lbs.)	ϕV_{cb} or ϕV_{cp} Shear (lbs.)	ϕN_{cb} or ϕN_a Tension (lbs.)	ϕV_{cb} or ϕV_{cp} Shear (lbs.)	ϕN_{cb} or ϕN_a Tension (lbs.)	ϕV_{cb} or ϕV_{cp} Shear (lbs.)	ϕN_{cb} or ϕN_a Tension (lbs.)	ϕV_{cb} or ϕV_{cp} Shear (lbs.)
3/8 or #3	2-3/8	1,580	1,705	1,615	1,740	1,675	1,805	1,760	1,895	1,820	1,960
	3	2,000	2,565	2,045	2,810	2,115	3,245	2,220	3,975	2,300	4,590
	4-1/2	3,000	4,255	3,065	4,660	3,170	5,380	3,330	6,590	3,445	7,425
1/2 or #4	2-3/4	2,445	2,480	2,495	2,715	2,585	3,135	2,715	3,840	2,810	4,435
	4	3,555	4,230	3,630	4,630	3,760	5,350	3,945	6,550	4,085	7,565
	6	5,330	7,150	5,450	7,835	5,640	9,045	5,920	11,080	6,130	12,795
5/8 or #5	3-1/8	3,470	3,260	3,545	3,570	3,670	4,125	3,855	5,050	3,990	5,830
	5	5,550	6,420	5,675	7,030	5,875	8,120	6,165	9,945	6,385	11,480
	7-1/2	8,330	10,945	8,510	11,990	8,810	13,840	9,250	16,955	9,575	19,575
3/4 or #6	3-1/2	4,665	4,350	4,765	4,765	4,935	5,500	5,180	6,740	5,360	7,780
	6	7,995	9,365	8,170	10,255	8,460	11,845	8,880	14,505	9,190	16,750
	9	11,990	15,905	12,255	17,425	12,690	20,120	13,320	24,640	13,790	28,455
7/8 or #7	3-1/2	5,105	4,770	5,560	5,225	5,755	6,035	6,045	7,395	6,255	8,535
	7	10,880	12,685	11,120	13,895	11,515	16,045	12,085	19,650	12,510	22,690
	10-1/2	16,320	21,580	16,685	23,640	17,270	27,295	18,130	33,430	18,765	38,600
1 or #8	4	6,240	6,195	6,660	6,790	6,895	7,840	7,240	9,600	7,495	11,085
	8	13,035	16,510	13,325	18,085	13,795	20,885	14,480	25,580	14,990	29,535
	12	19,555	28,115	19,985	30,795	20,690	35,560	21,720	43,555	22,485	48,425
#9	4-1/2	7,195	8,090	7,355	8,860	7,615	10,230	7,990	12,530	8,275	14,465
	9	14,390	21,295	14,710	23,325	15,225	26,935	15,985	32,985	16,545	35,635
	13-1/2	21,585	36,065	22,065	39,510	22,840	45,620	23,975	51,640	24,820	53,455
1-1/4	5	8,145	9,605	8,325	10,525	8,615	12,150	9,045	14,880	9,360	17,185
	10	16,285	25,670	16,645	28,125	17,230	32,475	18,090	38,960	18,725	40,330
	15	24,430	43,775	24,970	47,950	25,845	55,370	27,135	58,440	28,085	60,495
#10	5	8,145	9,915	8,325	10,860	8,615	12,545	9,045	15,360	9,360	17,740
	10	16,285	26,175	16,645	28,675	17,230	33,110	18,090	38,960	18,725	40,330
	15	24,430	44,390	24,970	48,625	25,845	55,665	27,135	58,440	28,085	60,495

Legend Concrete Breakout Strength Bond Strength/Pryout Strength

Factored bond or concrete strength must be checked against factored steel strength to determine the controlling ultimate load.
 Factored tension design strength = $\min | \phi N_{cb} \text{ or } \phi N_a \text{ or } \phi N_{sa} |$ and factored shear design strength = $\min | \phi V_{cb} \text{ or } \phi V_{cs} \text{ or } \phi V_{cp} |$

ADHESIVES

STRENGTH DESIGN PERFORMANCE DATA

Tension and Shear Design Strength Installed in Cracked Concrete, Drilled with a Hammer-Drill and Carbide Bit in a Dry Hole Condition, for Temperature Range A (Bond or Concrete Strength)

Maximum long term service temperature = 75°F (24°C), Maximum short term service temperature = 104°F (40°C)



ADHESIVES

Minimum Concrete Compressive Strength, f'c (psi)											
Nominal Rod/Rebar Size (in. or #)	Embed. Depth h _{ef} (in.)	2,500		3,000		4,000		6,000		8,000	
		ϕN_{cb} or ϕN_a Tension (lbs.)	ϕV_{cb} or ϕV_{cp} Shear (lbs.)	ϕN_{cb} or ϕN_a Tension (lbs.)	ϕV_{cb} or ϕV_{cp} Shear (lbs.)	ϕN_{cb} or ϕN_a Tension (lbs.)	ϕV_{cb} or ϕV_{cp} Shear (lbs.)	ϕN_{cb} or ϕN_a Tension (lbs.)	ϕV_{cb} or ϕV_{cp} Shear (lbs.)	ϕN_{cb} or ϕN_a Tension (lbs.)	ϕV_{cb} or ϕV_{cp} Shear (lbs.)
1/2 or #4	2-3/4	2,445	1,770	2,500	1,940	2,585	2,240	2,715	2,740	2,810	3,165
	4	3,555	3,020	3,635	3,310	3,765	3,820	3,950	4,680	4,090	5,405
	6	5,335	5,110	5,455	5,595	5,645	6,460	5,925	7,915	6,135	9,140
5/8 or #5	3-1/8	3,050	2,330	3,345	2,550	3,825	2,945	4,020	3,610	4,160	4,165
	5	5,790	4,585	5,915	5,020	6,125	5,800	6,430	7,100	6,655	8,200
	7-1/2	8,680	7,815	8,875	8,565	9,185	9,885	9,645	12,110	9,980	13,985
3/4 or #6	3-1/2	3,620	3,105	3,965	3,405	4,575	3,930	5,400	4,815	5,590	5,555
	6	8,120	6,690	8,520	7,325	8,820	8,460	9,260	10,360	9,585	11,965
	9	12,500	11,360	12,780	12,445	13,225	14,370	13,885	17,600	14,375	20,325
7/8 or #7	3-1/2	3,620	3,410	3,965	3,735	4,575	4,310	5,605	5,280	6,470	6,095
	7	10,230	9,060	11,210	9,925	12,000	11,460	12,600	14,035	13,045	16,210
	10-1/2	17,015	15,415	17,395	16,885	18,005	19,495	18,900	23,880	19,565	27,570
1 or #8	4	4,420	4,425	4,840	4,850	5,590	5,600	6,845	6,860	7,905	7,920
	8	12,500	11,795	13,695	12,920	15,675	14,920	16,460	18,270	17,035	21,095
	12	22,225	20,080	22,715	21,995	23,515	25,400	24,685	31,110	25,555	35,920
#9	4-1/2	5,275	5,775	5,780	6,330	6,670	7,305	8,170	8,950	9,435	10,335
	9	14,920	15,210	16,340	16,660	18,870	19,240	21,085	23,560	21,825	27,205
	13-1/2	27,405	25,760	29,100	28,220	30,120	32,585	31,625	39,910	32,735	46,085
1-1/4	5	6,175	6,860	6,765	7,515	7,815	8,680	9,570	10,630	11,050	12,275
	10	17,470	18,335	19,140	20,090	22,100	23,195	26,030	28,410	26,940	32,805
	15	32,095	31,265	35,160	34,250	37,190	39,550	39,040	48,435	40,415	55,930
#10	5	6,175	7,085	6,765	7,760	7,815	8,960	9,570	10,970	11,050	12,670
	10	17,470	18,695	19,140	20,480	22,100	23,650	26,030	28,965	26,940	33,445
	15	32,095	31,705	35,160	34,735	37,190	40,105	39,040	49,120	40,415	56,720

Legend Concrete Breakout Strength Bond Strength/Pryout Strength

STRENGTH DESIGN PERFORMANCE DATA

Tension and Shear Design Strength Installed in Cracked Concrete, Drilled with a Hammer-Drill and Carbide Bit in a Dry Hole Condition, for Temperature Range B (Bond or Concrete Strength)

Maximum long term service temperature = 122°F (50°C), Maximum short term service temperature = 176°F (80°C)



Minimum Concrete Compressive Strength, f'c (psi)											
Nominal Rod/Rebar Size (in. or #)	Embed. Depth h _{ef} (in.)	2,500		3,000		4,000		6,000		8,000	
		ϕN_{cb} or ϕN_a Tension (lbs.)	ϕV_{cb} or ϕV_{cp} Shear (lbs.)	ϕN_{cb} or ϕN_a Tension (lbs.)	ϕV_{cb} or ϕV_{cp} Shear (lbs.)	ϕN_{cb} or ϕN_a Tension (lbs.)	ϕV_{cb} or ϕV_{cp} Shear (lbs.)	ϕN_{cb} or ϕN_a Tension (lbs.)	ϕV_{cb} or ϕV_{cp} Shear (lbs.)	ϕN_{cb} or ϕN_a Tension (lbs.)	ϕV_{cb} or ϕV_{cp} Shear (lbs.)
1/2 or #4	2-3/4	1,520	1,770	1,555	1,940	1,605	2,240	1,685	2,740	1,745	3,165
	4	2,210	3,020	2,260	3,310	2,340	3,820	2,455	4,680	2,540	5,405
	6	3,315	5,110	3,390	5,595	3,505	6,460	3,680	7,915	3,810	8,210
5/8 or #5	3-1/8	2,245	2,330	2,295	2,550	2,375	2,945	2,495	3,610	2,580	4,165
	5	3,595	4,585	3,670	5,020	3,800	5,800	3,990	7,100	4,130	8,200
	7-1/2	5,390	7,815	5,510	8,565	5,700	9,885	5,985	12,110	6,195	13,345
3/4 or #6	3-1/2	3,020	3,105	3,085	3,405	3,195	3,930	3,350	4,815	3,470	5,555
	6	5,175	6,690	5,290	7,325	5,475	8,460	5,745	10,360	5,950	11,965
	9	7,760	11,360	7,930	12,445	8,210	14,370	8,620	17,600	8,925	19,220
7/8 or #7	3-1/2	3,520	3,410	3,600	3,735	3,725	4,310	3,910	5,280	4,050	6,095
	7	7,040	9,060	7,195	9,925	7,450	11,460	7,820	14,035	8,095	16,210
	10-1/2	10,565	15,415	10,795	16,885	11,175	19,495	11,735	23,880	12,145	26,160
1 or #8	4	4,420	4,425	4,700	4,850	4,865	5,600	5,110	6,860	5,285	7,920
	8	9,195	11,795	9,400	12,920	9,730	14,920	10,215	18,270	10,575	21,095
	12	13,795	20,080	14,100	21,995	14,595	25,400	15,325	31,110	15,860	34,165
#9	4-1/2	5,275	5,775	5,780	6,330	6,160	7,305	6,465	8,950	6,690	10,335
	9	11,640	15,210	11,900	16,660	12,315	19,240	12,930	23,560	13,385	27,205
	13-1/2	17,460	25,760	17,845	28,220	18,475	32,585	19,395	39,910	20,075	43,240
1-1/4	5	6,175	6,860	6,765	7,515	7,600	8,680	7,980	10,630	8,260	12,275
	10	14,370	18,335	14,690	20,090	15,205	23,195	15,965	28,410	16,525	32,805
	15	21,555	31,265	22,035	34,250	22,805	39,550	23,945	48,435	24,785	53,385
#10	5	6,175	7,085	6,765	7,760	7,600	8,960	7,980	10,970	8,260	12,670
	10	14,370	18,695	14,690	20,480	15,205	23,650	15,965	28,965	16,525	33,445
	15	21,555	31,705	22,035	34,735	22,805	40,105	23,945	49,120	24,785	53,385

Legend Concrete Breakout Strength Bond Strength/Pryout Strength

ADHESIVES

STRENGTH DESIGN PERFORMANCE DATA



Tension Design of Steel Elements (Steel Strength)

Steel Elements - Threaded Rod and Reinforcing Bar											
Nominal Rod/Rebar Size (in. or No.)	A36 and F1554, Grade 36	F1554, Grade 55	A449	A193, Grade B7	F593 Condition CW	A 193 Grade B8/B8M, Class 1	A 193 Grade B8/B8M2, Class 2B	A615, Grade 75	A615, Grade 60	A706, Grade 60	A615, Grade 40
	ϕN_{sa} Tension (lbs.)	ϕN_{sa} Tension (lbs.)	ϕN_{sa} Tension (lbs.)	ϕN_{sa} Tension (lbs.)	ϕN_{sa} Tension (lbs.)	ϕN_{sa} Tension (lbs.)	ϕN_{sa} Tension (lbs.)	ϕN_{sa} Tension (lbs.)	ϕN_{sa} Tension (lbs.)	ϕN_{sa} Tension (lbs.)	ϕN_{sa} Tension (lbs.)
3/8 or #3	3,395	4,390	7,020	7,315	5,070	4,390	5,560	7,150	6,435	6,600	4,290
1/2 or #4	6,180	7,990	12,780	13,315	9,230	7,990	10,120	13,000	11,700	12,000	7,800
5/8 or #5	9,830	12,715	20,340	21,190	14,690	12,715	16,105	20,150	18,135	18,600	12,090
3/4 or #6	14,575	18,845	30,150	31,405	21,775	18,845	23,870	28,600	25,740	26,400	17,160
7/8 or #7	20,100	25,990	41,580	43,315	30,030	25,990	32,920	39,000	35,100	36,000	23,400
1 or #8	26,360	34,090	54,540	56,815	39,390	34,090	43,180	51,350	46,215	47,400	30,810
#9	-	-	-	-	-	-	-	65,000	58,500	60,000	39,000
1-1/4	42,150	54,505	87,210	90,845	62,985	54,505	69,040	-	-	-	-
#10	-	-	-	-	-	-	-	82,550	74,295	76,200	49,530

Legend Steel Strength

Shear Design of Steel Elements (Steel Strength)

Steel Elements - Threaded Rod and Reinforcing Bar											
Nominal Rod/Rebar Size (in. or No.)	A36 and F1554, Grade 36	F1554, Grade 55	A449	A193, Grade B7	F593 Condition CW	A 193 Grade B8/B8M, Class 1	A 193 Grade B8/B8M2, Class 2B	A615, Grade 75	A615, Grade 60	A706, Grade 60	A615, Grade 40
	ϕV_{sa} Shear (lbs.)	ϕV_{sa} Shear (lbs.)	ϕV_{sa} Shear (lbs.)	ϕV_{sa} Shear (lbs.)	ϕV_{sa} Shear (lbs.)	ϕV_{sa} Shear (lbs.)	ϕV_{sa} Shear (lbs.)	ϕV_{sa} Shear (lbs.)	ϕV_{sa} Shear (lbs.)	ϕV_{sa} Shear (lbs.)	ϕV_{sa} Shear (lbs.)
3/8 or #3	1,765	2,280	3,650	3,805	2,810	2,280	2,890	3,960	3,565	3,430	2,375
1/2 or #4	3,210	4,155	6,645	6,925	5,110	4,155	5,260	7,200	6,480	6,240	4,320
5/8 or #5	5,110	6,610	10,580	11,020	8,135	6,610	8,375	11,160	10,045	9,670	6,695
3/4 or #6	7,580	9,800	15,680	16,330	12,060	9,800	12,410	15,840	14,255	13,730	9,505
7/8 or #7	10,450	13,515	21,620	22,525	16,630	13,515	17,120	21,600	19,440	18,720	12,960
1 or #8	13,710	17,725	28,360	29,545	21,815	17,725	22,450	28,440	25,595	24,650	17,065
#9	-	-	-	-	-	-	-	36,000	32,400	31,200	21,600
1-1/4	21,920	28,345	45,350	47,240	34,885	28,345	35,900	-	-	-	-
#10	-	-	-	-	-	-	-	45,720	41,150	39,625	27,430

Legend Steel Strength

ADHESIVES

ORDERING INFORMATION

AC100+ Gold Cartridges

Cat No.	Description	Std. Box	Std. Carton	Pallet
8462SD	AC100+ Gold 5 fl. oz. Push-Pak (DIY series)	12	36	-
8478SD	AC100+ Gold 10 fl. oz. Quik-Shot (DIY series)	12	-	972
8480SD	AC100+ Gold 8 fl. oz. dual cartridge	12	-	576
8486SD	AC100+ Gold 12 fl. oz. dual cartridge	12	-	864
8490SD	AC100+ Gold 28 fl. oz. dual cartridge	8	-	400

One AC100+ Gold mixing nozzle is packaged with each cartridge.
AC100+ Gold mixing nozzles must be used to ensure complete and proper mixing of the adhesive.

Cartridge System Mixing Nozzles

Cat No.	Description	Std. Pack/Box	Std. Carton
08293	Extra mixing nozzle for AC100+ Gold (5 oz., 8 oz., 10 oz. & 12 oz.)	2	24
08294	Extra mixing nozzle (with a 8" extension) for AC100+ Gold 28 oz.	2	24
08281	Mixing nozzle extension, 8" minimum	2	24

Dispensing Tools for Injection Adhesive

Cat No.	Description	Std. Box	Std. Carton
08437	Manual caulking gun for Push-Pak and Quik-Shot	1	12
08479	High performance caulking gun for Push-Pak and Quik-Shot	1	6
08484	AC100+ Gold 8 oz. standard all metal manual tool	1	6
08485	AC100+ Gold 8 oz., 10 oz. & 12 oz. high performance manual tool	1	20
08494	AC100+ Gold 28 oz. standard all metal manual tool	1	-
08496	AC100+ Gold 28 oz. pneumatic tool	1	-
08444	AC100+ Gold 28 oz. cordless power tool	1	-

Hole Cleaning Tools and Accessories

Cat No.	Description	Std. Box
08284	Wire brush for 7/16" ANSI hole (3/8" rod or #3 rebar), 6-3/4" length	1
08285	Wire brush for 9/16" ANSI hole (1/2" rod or #4 rebar), 6-3/4" length	1
08286	Wire brush for 11/16" ANSI hole (5/8" rod or #5 rebar), 7-7/8" length	1
08278	Wire brush for 3/4" ANSI hole (5/8" rod or #5 rebar), 7-7/8" length	1
08287	Wire brush for 7/8" ANSI hole (3/4" rod or #6 rebar), 7-7/8" length	1
08288	Wire brush for 1" ANSI hole (7/8" rod or #7 rebar), 11-7/8" length	1
08289	Wire brush for 1-1/8" ANSI hole (1" rod or #8 rebar), 11-7/8" length	1
08290	Wire brush for 1-3/8" ANSI hole (1-1/4" rod or #9 rebar), 11-7/8" length	1
08291	Wire brush for 1-1/2" ANSI hole (#10 rebar), 11-7/8" length	1
08283	SDS-plus adapter for steel brushes	1
08296	Standard drill adapter for steel brushes (e.g. Jacobs Chuck)	1
08282	Steel brush extension, 12" length	1
08280	Hand pump/dust blower (25 fl. oz. cylinder volume)	1
08292	Air compressor nozzle with extension, 18" length	1
08465	Adjustable torque wrench with 1/2" square drive (10 to 150 ft.-lbs.)	1
08466	Adjustable torque wrench with 1/2" square drive (25 to 250 ft.-lbs.)	1
52073	Adhesive cleaning kit, includes 4 wire brushes (08284, 08285, 08286, 08287), steel brush extension (08282), SDS-plus adapter (08283), standard drill adapter (08296), hand pump/dust blower (08280), gloves and safety glasses	1



ADHESIVES

ORDERING INFORMATION

Adhesive Pistons

Cat. No.	Description	ANSI Drill Dia.	Reinforcing Bar Size	Threaded Rod Size	Std. Bag	Std. Ctd.
08300	7/8" Plug	7/8"	#6	3/4"	10	100
08301	1" Plug	1"	#7	7/8"	10	100
08303	1-1/8" Plug	1-1/8"	#8	1"	10	100
08305	1-3/8" Plug	1-3/8"	#9	1-1/4"	10	100
08309	1-1/2" Plug	1-1/2"	#10	-	10	100



Stainless Steel Screen Tubes

Cat. No.	Description	Drill Diameter	Standard Carton
07961	3/8" x 3-1/2" Screen Tube	1/2"	25
07962	3/8" x 6" Screen Tube*	1/2"	25
07963	3/8" x 8" Screen Tube*	1/2"	25
07964	3/8" x 10" Screen Tube*	1/2"	25
07959	3/8" x 12" Screen Tube*	1/2"	25
07965	1/2" x 3-1/2" Screen Tube	5/8"	25
07966	1/2" x 6" Screen Tube*	5/8"	25
07967	1/2" x 8" Screen Tube*	5/8"	25
07968	1/2" x 10" Screen Tube*	5/8"	25
07969	5/8" x 4-1/2" Screen Tube	3/4"	20
07970	5/8" x 6" Screen Tube	3/4"	20
07971	5/8" x 8" Screen Tube*	3/4"	20
07972	5/8" x 10" Screen Tube*	3/4"	20



Screen tubes are made from a 300 series stainless steel. The nominal diameter of the screen listed indicates the matching rod diameter.
 *Includes extension tubing.

Plastic Screen Tubes

Cat. No.	Description	Drill Diameter	Standard Carton
08473	3/8" x 2-3/4" Plastic Screen	9/16"	25
08310	3/8" x 3-1/2" Plastic Screen	9/16"	25
08311	3/8" x 6" Plastic Screen	9/16"	25
08313	3/8" x 8" Plastic Screen	9/16"	25
08315	1/2" x 3-1/2" Plastic Screen	3/4"	25
08317	1/2" x 6" Plastic Screen	3/4"	25
08321	5/8" x 6" Plastic Screen	7/8"	25



ADHESIVES